

PAKISTAN AERONAUTICAL COMPLEX, KAMRA MIRAGE REBUILD FACTORY

TENDER NOTICE NO MRF/17-18/06 DATED 01 January, 2018.

1. Mirage Rebuild Factory, Pakistan Aeronautical Complex Board Kamra invites sealed bids from the Original manufacturer / authorized distributors / suppliers / contractor registered with Income Tax and Sales Tax Department and PACB registered for supply of following miscellaneous items on F.O.R Basis (Professional Tax certificate, Punjab is mandatory). Details of requirements is as follows:-

“RUBBER MAT 1/4 INCH, RACK STORAGE STEEL 6X6X3 FT, RACK STORAGE STEEL, PHOTOSTATE MACHINE RICOH MP3054, OIL, OIL SEPARATOR ELEMENT, BONDED SEAL, O RING, AIR FILTER, 2000 HOURS OIL, CALIBRATING FLUID, MONOCHROME LASER PRINTER EPSON EPL-N2500, STAINLESS STEEL SHEET 0.110 INCH, STAINLESS STEEL SHEET 0.040INCH, GAUGE PRESSURE (0-300PSIG), GAUGE PRESSURE (0-100PSIG), POWDER FEED HOSE, POTENTIOMETER, FIXTURE, FIXTURE, FIXTURE, FIXTURE, POWER PORT SH, SOLDERING FLUX, DEFT CHEMICAL PAINT, GENERAL SERVICE SET, POTASSIUM PER MAGNATE, LUBRICATING OIL SHELL CORENA H-68, SEL SWITCH 2-POS, MOLY STUD 10-32 UNF X 5/8 INCH, MOLY NUT HEX 10-32 UNF, BATTERY 12 V 150AH, HEATER, TEMPERATURE CONTROL UNIT ASSY, ADAPTER LIFTING, DTI, DEPTH MICROMETER SET, GI SHEET 8X4 FTX22SWG, STRAIGHT BAR, FAN HOLDING FIXTURE, WIRE GUAGE SET, TESA TRI-O-BAR, TESA TRI-O-BAR, COMPRESSOR HOLDING FIXTURE, COMPRESSOR HOLDING FIXTURE, TURBINE HOLDING FIXTURE, K NOZZLE, ALLUMINIUM PLATE 8FTX 4FTX 50MM, TEMPERATURE TRANSMITTER, NOZZLE1/8 ACCTYLENE, COUNTER SHAFT GEAR, TORQUE WRENCH 100-250 FT LBS, WROUGHT MAGNESIUM ALLOY, CARTIDGE END MILL CUTTER1 INCH, INSP LIGHT LAMP, BEARING BALL, WIRE WELDING, CONNECTOR MAINTANCE KIT, PACKING MK-4 EJECTION SEAT, PACKING MK-6 EJECTION SEAT, BRAZING MATERIAL, RATCHET SET 3 REVERSIBLE, AIR PRESSURE REGULATOR FOI NITROGEN, NICKLE POWDER (COMPONENT FOR PWA544-1), CYLINDER HYDROGEN, GRAPHITE VARNISH, ACTIVATOR, PRIMER (GREEN EPOXY), REGULATOR NITROGEN, ELECT OVEN, BLACK NYLON RIBBON, PRIMER ENCAPSULATING AND POTTING, EVOSTICK 529, UPS 2KVA, COMPUTER INTEL CORE I7 3.4 GHZ OR HIGHER (BRANDED), TRANSFORMER, SHEILD HEAT T/M OUTER MEMBER, NEEDLE NOSE, SCRIBER, TEST RIG MACHINE (L/R), STAINLESS STEEL ROD (0.50INCH), LIQUID LINE FLOW METER CALIBRATION SYSTEM (L/R), METHYLE KETONE, VARNISH, RIBBON, DIGITAL HIGH GUAGE, IRON RACK 6X6X3 FEET WITH WHEEL CASTER, X-RAY FILM 35.6X43.2CM, X-RAY FILM 18X24 CM, X-RAY FILM 24X30 CM, A/C REFULER (L/R), WALKIE TALKI SET REPEATER, TELEPHONE SET(3902), PRESSURE LIMITING VALVES MV41 BR/0.500 BAR+M18X1.5, PLIERS DIAGONAL GROUNDING, WORKING TABLE”.

2. List of items can also be downloaded from PPRA website www.ppra.org.pk and as well as PACB website www.pac.org.pk free of cost or can be collected from DTE of Log (LP Section) MRF PAC Kamra Distt Attock from 02-01-2018 during working hours (except holidays).

3. The quotations, prepared in accordance with the instruction in the Tender List, must reach at Mirage Rebuild Factory PACB Kamra **before 16-01-2018 at 1000 Hrs. Quotations will be opened on the same day at 1100 Hrs.** The advertisement is also available on PPRA website at www.ppra.org.pk and as well as PACB website www.pac.org.pk



DUE DATE : 16-01-2018 before 1000 Hrs.
TENDER OPENING TIME : 16-01-2018 at 1100 Hrs.

Please contact **Tele # 051-9099-4294 / 4414, 4417** or **Fax No 057-9317412** for any other information.

**DIRECTOR LOGISTICS
MRF PACB KAMRA
DISTT ATTOCK**

**Directorate of Logistics MRF, PAC Kamra
Contact No. 051-90994294, 4414 & 4417, Fax No. 057-9317412**



**LIST OF OPEN TENDER NO MRF/17-18/06
DATED 01-01-2018 OPENING DATE 16-01-2018**

SN O	PART NO	NOUN	QTY	U/I	SPECIFICATION
1	32C/598B	RUBBER MAT 1/4 INCH	600	KG	RUBBER MAT 1/4 INCH
2	9640/PK0740002	RACK STORAGE STEEL 6X6X3 FT	12	EA	SIZE: 6 FT HEIGHT X6 FT WIDTHX3 FT DEEP RACK IS DIVIDED IN FOUR SHELVES ANGLE THICKNESS 3MM M/S SHEET 1.25MM
3	9520PK0960005	RACK STORAGE STEEL	4	EA	SIZE: 5 FT LENGTHX2 FT WIDTHX3.6 FT HEIGHT RACK IS DIVIDED IN THREE SHELVES (PLY THICKNESS 1 INCH)
4	MP3054	PHOTOSTATE MACHINE RICOH MP3054	1	EA	PHOTOSTATE MACHINE RICOH MP3054
5	AEON3000	OIL	10	LTR	AEON3000 OIL GARDNER DENVER EQUIVALENT OR HIGHER MSDS/TDS/ REMAINING SHELF LIFE CERTIFICATE ALSO REQUIRED
6	PMC/57029	OIL SEPARATOR ELEMENT	1	EA	REQUIRED FOR COMP AIR COMPRESSOR/TDS,MSDS ALSO REQUIRED
7	9619	BONDED SEAL	1	EA	REQUIRED FOR COMP AIR COMPRESSOR/TDS,MSDS ALSO REQUIRED
8	9831	O RING	1	EA	REQUIRED FOR COMP AIR COMPRESSOR/TDS,MSDS ALSO REQUIRED
9	57019	AIR FILTER	1	EA	REQUIRED FOR COMP AIR COMPRESSOR/TDS,MSDS ALSO REQUIRED
10	AUX-2000	2000 HOURS OIL	5	LTR	REQUIRED FOR COMP AIR COMPRESSOR/TDS,MSDS ALSO REQUIRED,75 % REMAINING SHELF LIFE CERTIFICATE,OEM CONFIRMANCE CERTIFICATE IS ALSO REQUIRED
11	MIL-C-7024	CALIBRATING FLUID	55	GL	FLASH POINT: <170 F BOILING POINT: 310-405 F SPECIFIC GRAVITY: <1.0 VAPOR DENSITY: >1.0 EVAPORATION RATE: < 1.0 ETHER SOLUBILITY IN WATER: NEGLIGIBLE MSDS ALSO REQUIRED,75 % REMAINING SHELF LIFE CERTIFICATE,OEM CONFIRMANCE CERTIFICATE IS ALSO REQUIRED



PAKISTAN AERONAUTICAL COMPLEX
3 A SYMBOL OF EXCELLENCE IN AVIATION
www.pac.org.pk



12	21B/7010PK0006	MONOCHROME LASER PRINTER EPSON EPL-N2500	5	EA	MONOCHROME LASER PRINTER EPSON EPL-N2500 EQUIVALENT OR HIGHER
13	AMS5646-0.110INCH	STAINLESS STEEL SHEET 0.110 INCH	1	SH	STAINLESS STEEL SHEET 0.110 INCH THICKNESS
14	AMS5646-0.040INCH	STAINLESS STEEL SHEET 0.040INCH	1	SH	STAINLESS STEEL SHEET 0.040 INCH THICKNESS
15	1082XEY0-300PSIG	GAUGE PRESSURE (0-300PSIG)	1	EA	ACCURACY: +, - 0.25 % CASE SIZE : 6" CONNECTION: BACK CONNECTED 1/4 " RANGE: 0-300PSI SUB D: 1 PSI MANUFACTURER: ASHCROFT USA /EQUIVALENT OR HIGHER
16	1082XEY0-100PSIG	GAUGE PRESSURE (0-100PSIG)	1	EA	ACCURACY: +, - 0.25 % CASE SIZE : 6" CONNECTION: BACK CONNECTED 1/4 " RANGE: 0-100PSI SUB D: 1 PSI MANUFACTURER: ASHCROFT USA/EQUIVALENT OR HIGHER BRONZE TUBE,BROSS SOCKET,BRAZED
17	4MP195	POWDER FEED HOSE	1	EA	MAKE : METCO OR EQUIVALENT COLOUR: BLACK LENGTH : 9 FT
18	P13VPEAM10K10	POTENTIOMETER	15	EA	
19	3G6220A00332-HUB	FIXTURE	1	EA	SUPPORTING TOOL,M/R ROTATING SWASHPLATE BUSHINGS IN-LINE REAMER MILLING. SUPPORT TOOL ALLOW LOCKING OF P/N 3G6230A00332 ON MACHINARY FOR FLAHDGED BUSHINGS IN-LINE REAMER AND MILLING MATERIAL REF:LOCKING PLATE: CARBON STEEL SAE 1020(REF)-APPLY SURFACE TREATMENT LOCKING PLATE: CARBON STEEL SAE 1020(REF)-APPLY SURFACE TREATMENT SPACER:CARBON STEEL SAE 1020(REF)-APPLY SURFACE TREATMENT THREADED PIVOT:STEEL ALLOY AISI 4140(REF) APPLY SURFACE TREATMENT SPECIAL WASHER: STEEL ALLOY AISI 4130(REF) APPLY SURFACE TREATMENT ALIGNMENT PIN: STEEL ALLOY AISI 4140(REF)OR EQUIVALENT (*) POSITIONING PIN : STEEL ALLOY AISI 4140



PAKISTAN AERONAUTICAL COMPLEX
4 A SYMBOL OF EXCELLENCE IN AVIATION
www.pac.org.pk



					OR EQUIVALENT(*) 1) MATERIAL SHOWN WITH (*) MUST BE USED.2) MATERIAL USED MUST ENSURE SIMILAR FEATURES DIMENSION SHOWN AS REF . DEPENDING TO THE MACHINERY INTERFACE AND DIFFERENT COMPONENT SELECTED. DIAGRAM ATTACHED AT THE END OF THIS TENDER.(2 of 20)
20	3G6220A00632- FLANG	FIXTURE	1	EA	SUPPORT TOOL ALLOW LOCKING OF P/N 3G6220A00632 (AND SUBS) ON MACHINERY FOR FLANGED BUSHING MILLING AND IN-LINE REAMER MATERIAL REFENCE: LOCKING PLATE : CARBON STEEL SAE 1020 (REF) APPLY SURFACE TREATMENT ALLIGNMENT PIN: STEEL ALLOY AISI 4130(REF) APPLY SURFACE TREATMENT WASHER : BRASS ALLOY 1) MATERIAL SHOWN AS REF, ARE RECOMENDED DIFFERENT MATERIAL USED MUST BE ENSURE SIMILAR FEATURE DIMENSIONAL REF: DIMENSION SHOWN AS REF, DEPENDING TO THE MACHINERY INTERFACE AND DIFFERENT COMPONENT SELECTED.DIAGRAM SHOWN AT THE END OF THIS TENDER (2 of 4)
21	3G6230A00332- SWASH	FIXTURE	1	EA	SUPPORT TOOL ALLOW LOCKING OF PIN 3G6230A00332 ON MACHINERY FOR FLANGED BUSHING IN-LINE REAMER AND MILLINGMATERIAL REFENCE : LOCKING PLATE : CARBON STEEL SAE 1020(REF) .APPLY SURFACE TREATMENT LOCKING PLATE:CARBON STEEL SAE 1020(REF) APPLY SURFACE TREATMENT SPACER: CARBON STEEL SAE 1020 (REF)- APPLY SURFACE TREATMENT THREADED PIVOT: STEEL ALLOY AISI 4140 (REF) APPLY SURFACE TREATMENT SPECIAL WASHER :STEEL ALLOY AISI 4130 (REF) APPLY SURFACE TREATMENT ALLINGMENT PIN: STEEL ALLOY AISI OR EQUIVALENT(*) POSITIONING PIN: STEL ALLOY AISI 4140 OR EQUIVALENT(*) 1) MATERIAL , SHOWN WITH (*) MUST BE



PAKISTAN AERONAUTICAL COMPLEX
5 A SYMBOL OF EXCELLENCE IN AVIATION
www.pac.org.pk



					USED 2) MATERIAL SHOWN AS REF. ARE RECOMENDED DIFFERENT MATERIAL USED MUST BE SIMILAR FEATURE DIMENSIONAL REF: 1) DIMENSION SHOWN AS REF. DEPENDING TO THE MACHINARY INTERFACE AND DIFFERENT COMPONENT SELECTED.DIAGRAM SHOWN AT THE END OF THIS TENDER (2 of 9)
22	3G6430A00335-TAIL	FIXTURE	1	EA	SUPPORT TOOL ALLOW LOCKING OF PIN 3G6430S00335 ON MSCHINSRY FOR FLANGED BUSHING IN-LINE REAMER MATERIAL REF: LOCKING PLATE: CARBON STEEL SAE 1020(REF) .APPLY SURFACE TREATMENT LOCKING BRACKET : CARBON STEEL SAE 1020 (REF).APPLY SURFACE TREATMENT ALIGNMENT PINS: STEEL ALLOY AISI 4130 (REF) .APPLY SURFACE TREATMENT 1) MATERIAL SHOWN AS REFENCE ARE RECOMENDED DIFFERENT MATERIAL USED MUST ENSURE SIMILAR FEATURE DIMENSIONAL REF: DIMENSION SHOWN AS REF DEPENDING TO THE MACHINARY TO THE MACHINARY INTEFACE AND DIFFERENT COMPONENT SELECTED.DIAGRAM SHOWN AT THE END OF THIS TENDER.(2 of 7)
23	4MP156	POWER PORT SH	1	EA	MAKE METCO OR EQUIVALENT
24	MIL-F-14256	SOLDERING FLUX	2	EA	MIL-F-14256 TYPE A AND 50/50 TIN LEAD SOLDER
25	03-GY-401	DEFT CHEMICAL PAINT	5	KIT	MSDS/ TDS / REMAINING SHELF CERTIFICATE IS REQUIRED
26	292F/12POINT	GENERAL SERVICE SET	1	EA	PT NO292F/12POINT MADE SNAP ON OR EQUIVALENT
27	6850PK1990006	POTASSIUM PER MAGNATE	500	KG	APPEARANCE : DARK PURPLE -VIOLET CRYSTAL COMPOSITION: ELEMENT KMNO4 98% MIN IMPURITIES (CE-) 0.05% MAX LIMITS (IM WEIGHT)
28	AUX-0268	LUBRICATING OIL SHELL CORENA H-68	25	LTR	REQUIRED OF COMPRESSOR COMPARE MAKE UK-MOTIVAIR CAPACITY -37TO 45 KW TYPE V-150A OR EQUIVALENT/ msda/tds / remaining shelf life certificate required

	<p>PAKISTAN AERONAUTICAL COMPLEX 6 A SYMBOL OF EXCELLENCE IN AVIATION</p> <p>www.pac.org.pk</p>	
---	--	---

29	535935F	SEL SWITCH 2-POS	3	EA	
30	TR10M00-62	MOLY STUD 10-32 UNF X 5/8 INCH	50	EA	MOLY STUD 10-32 UNF X 5/8 INCH
31	MH7006	MOLY NUT HEX 10-32 UNF	100	EA	MOLY NUT HEX 10-32 UNF
32	6135PK2350000 1	BATTERY 12 V 150AH	14	EA	NIL
33	6797342	HEATER	1	EA	MAX TEMP REQUIRED 500 F (260 C) power output 1500 WATTS OPERATING VOLTAGE 240VOLTS
34	PWA25672N	TEMPERATURE CONTROL UNIT ASSY	1	EA	OPERATING VOLTAGE 240VOLT PWR OUTPUT 1500 WATT HEATER CONTROL 230 VOLT VARIABLE
35	6796539-202	ADAPTER LIFTING	1	EA	
36	IDS-188	DTI	1	EA	MADE FEDRAL USA OR EQUIVALENT
37	MICDEPTH6	DEPTH MICROMETER SET	1	EA	RANGE 0"-12" ACCURACY 0.0005"
38	30C/2292GI	GI SHEET 8X4 FTX22SWG	400	S/FT	GI SHEET 8X4 FTX22SWG
39	AXB101-501- 0009	STRAIGHT BAR	1	EA	
40	3078-1615	FAN HOLDING FIXTURE	2	EA	DIA 26" HEIGHT 9" THICKNESS 9MM
41	ST60880	WIRE GUAGE SET	1	EA	ACCURACY 0.0005 INCHES MAKE & MODEL JERAMES TOOLS MANUFACTURING SANTEE CALIFORNIA
42	06230033	TESA TRI-O-BAR	1	EA	A DIGITAL TESA TRI-O-BAR WITH RANGE 2"-2.75" IS PREFERABLE
43	06230034	TESA TRI-O-BAR	1	EA	A DIGITAL TESA TRI-O-BAR WITH RANGE 2.75"-3.50" IS PREFERABLE
44	3075-1612	COMPRESSOR HOLDING FIXTURE	3	EA	DIA 24" HEIGHT 4" THICKNESS 6MM
45	3076-1613	COMPRESSOR HOLDING FIXTURE	3	EA	DIA 22" HEIGHT 6" THICKNESS 6MM
46	3077-1614	TURBINE HOLDING FIXTURE	3	EA	DIA 20" HEIGHT 4" THICKNESS 6MM
47	6P7C-K	K NOZZLE	1	EA	MAKE METCO ORIGIN ABB COMPANY equivqalent or higher
48	7075-T6	ALLUMINIUM PLATE 8FTX 4FTX 50MM	2	EA	ALLUMINIUM PLATE 8FTX 4FTX 50MM
49	PT100	TEMPERATURE TRANSMITTER	1	EA	MADE MOORE IND OR EQUIVALENT



PAKISTAN AERONAUTICAL COMPLEX
 7 A SYMBOL OF EXCELLENCE IN AVIATION
www.pac.org.pk



50	12E7-3	NOZZLE 1/8 ACCTYLENE	1	EA	REQUIRED TO BE USED IN 16E SPRAY GUN
51	12E93-S	COUNTER SHAFT GEAR	1	EA	REQUIRED TO BE USED IN 16E SPRAY GUN
52	EVT3000A	TORQUE WRENCH 100-250 FT LBS	1	EA	
53	AZ-31B(2.5)	WROUGHT MAGNESIUM ALLOY	15	FT	
54	3B/522A	CARTIDGE END MILL CUTTER 1 INCH	5	EA	CARTIDGE END MILL CUTTER 1 INCH
55	5L/964690B	INSP LIGHT LAMP	4	EA	REQUIRED HIGHT 10 FT, CABLE LENGTH MIN 10MTR
56	202-R	BEARING BALL	12	EA	
57	AMS5030	WIRE WELDING	20	LB	WELD ROD AMS 5030
58	DMC440	CONNECTOR MAINTANCE KIT	1	EA	MODEL REQUIRED DMC440 MADE USA OR EQUIVALENT
59	BOX-MIR-MK-4	PACKING MK-4 EJECTION SEAT	1	EA	size/dim: 180x80x112 cm w.empty:tare 081 kg photograph/sample available at local purchase section MRF
60	BOX-MIR-PK- 0M6	PACKING MK-6 EJECTION SEAT	1	EA	size/dim: 180x80x112 cm w.empty:tare 081 kg photograph/sample available at local purchase section MRF
61	AMS2665	BRAZING MATERIAL	4	LB	PT NO AMS 2665
62	SJR151	RATCHET SET 3 REVERSIBLE	1	EA	PT NO SJR151
63	6D/1334A	AIR PRESSURE REGULATOR FOI NITROGEN	1	EA	MAX SUPPLY PRESSURE: 0-4000 PSI SAFETY LEVEL OPRAT : 300 PSI MATERIAL: STAINLESS STEEL MAKE/ MODEL: NISSAN TANAK OR EQUIVALENT
64	PWA1324	NICKLE POWDER (COMPONENT FOR PWA544-1)	10	LB	THERMOTEC 18976 (TO PWA 1324) MAKE/MODEL: EUTECTIC CORP/VERTEX VPC-23 SPECIAL METAL CORP/LA-4324 LINEAGE ALLOYS LLC OR EQUIVALENT
65	6125PK000516/D GMP	UNIVERSAL BATTERY CHARGER	1	EA	MADE NEXTEX OR EQUIVALENT
66	71A/32	CYLINDER HYDROGEN	10	CYL	CAPACITY 5.9NM, WORKING PRESSURE: 1980PSI QUALITY ACCEPTED CERTOFOCATE ALSO REQUIRED FROM M/S LINDE OR EQUIVALENT
67	G8450	GRAPHITE VARNISH	5	LTR	
68	930K097	ACTIVATOR	2	KG	MSDS REQUIRED



PAKISTAN AERONAUTICAL COMPLEX
8 A SYMBOL OF EXCELLENCE IN AVIATION
www.pac.org.pk



69	535K020	PRIMER (GREEN EPOXY)	1	GL	MSDS REQUIRED
70	7GNR1001449	REGULATOR NITROGEN	1	EA	OPERATING PRESSURE INLET PRESSURE CAPACITY:4500PSI OPERATING PRESSURE OUTLET PRESSURE CAPACITY:400 PSI CALIBRATION CERTIFICATE IS REQUIRED
71	UV240	ELECT OVEN	1	EA	
72	50607	BLACK NYLON RIBBON	3	EA	PART NO. 050607,NOUN. BLACK NYLON RIBBON
73	8010-66-050-2538	PRIMER ENCAPSULATING AND POTTING	3	EA	PART NO. 8010-66-050-2538
74	DTD900/4564	EVOSTICK 529	3	EA	PART NO. DTD900/4564,NOUN. EVOSTICK 529
75	SP2000DR	UPS 2KVA	1	EA	
76	21B/7010PK0850 8	COMPUTER INTEL CORE I7 3.4 GHZ OR HIGHER (BRANDED)	as required	EA	MOTHERBOARD:INTEL H81 CHIPSET (INTEL DH82H81 PCH) OR HIGHER PROCESSOR: INTEL I3-4160 PROCESSOR (3M CACHE, 3.60 GHZ) OR HIGHER RAM: 04 GB DDR-III OR MORE HARD DISK:500 GB SATA RPM OR MORE NETWORK CARD:10/100/1000 MBPS BUILT IN OR MORE KEYBOARD & MOUSE: BRANDED CASING: TOWER BRANDED POWER SUPPLY: BRANDED 450W OR HIGHER WITH BUILT IN 600/70100 VA SURGE PROTECTOR INSTALLED DISPLAY: 18.5 INCH LED MULTIMEDIA BRANDED OR HIGHER WARRANTY: OEM MINIMUM 03 YEARS
77	350096-42	TRANSFORMER	1	EA	PT NO 350096-42 INPUT 220VAC 1HP 5AM OUTPUT 110VAC 1HP 10AM
78	6796807	SHEILD HEAT T/M OUTER MEMBER	1	EA	PT NO 6796807
79	609ACP	NEEDLE NOSE	1	EA	PT NO 609ACP
80	YA338	SCRIBER	1	EA	PT NO YA338
81	RSP-951	TEST RIG MACHINE (L/R)	1	EA	SCOPE OF WORK NY1-DB22102:SAFETY RELAY 01EA NY1-DB14102:INTRINSIC SAFETY BLOCK 03 EA CA2-EN231B:CONTRACTOR RELAY 02 EA PM12/4: DIODE BRIDGE 02 EA KR30:TEMP SELECTOR SWITCH 6



PAKISTAN AERONAUTICAL COMPLEX
9 A SYMBOL OF EXCELLENCE IN AVIATION
www.pac.org.pk



					POSITION: 02 EA SRP7-04R1-0: NOZZLE RETURN LOAD VALVE: 02 EA
82	AMS-5744	STAINLESS STEEL ROD (0.50INCH)	2	FT	
83	PDCL-400	LIQUID LINE FLOW METER CALIBRATION SYSTEM (L/R)	1	EA	ON-SITE CALIBRATION OF LIQUID LINE FLOW METER CALIBRATION SYSTEM PART NO MODEL PDCL-400, (A) VISUALLY CHECK CYLINDER CONDITION AND MEASURE THE DIAMETER WITH NIST TRACEABLE STANDARD (B) MEASURE ENCODER CONSTANT OVER A KNOWN DISTANCE USING NIST TRACEABLE DOPPLER LASER (C) CHECK TEMPERATURE AGAINST NIST TRACEABLE STANDARD (D) CHECK TIME AND FREQUENCY AGAINST NIST TRACEABLE STANDARD (E) CHECK SYSTEM ANALOGUE INPUTS (VOLT & CURRENT) REPLACE PISTON SEAL REPLACE FILTERS LEAK TEST SYSTEM CHECK FLOW ACCURACY WITH CHECK STANDARD PROVIDE NVLAP CALIBRATION CERTIFICATE AND UNCERTAINTY ANALYSIS BOARDING / LIDGING OF ENGINEERS WILL BE BORNE BY SUPPLIER
84	MEK	METHYLE KETONE	420	LR	PURITY (WT%):99.5 SPECIFIC GRAVITY @20/20C: MINIMUM 0.805 MAXIMUM 0.805 SPECIFIC GRAVITY @:25/25C: MINIMUM 0.801 0.803 MAXIMUM WATER (WT%): MAXIMUM 0.1 ACIDITY AS ACETIC ACID (WT%): MAXIMUM 0.003 COLOR (PT-CO):10 DISTILLATION RANGE (DEGREES C) INITIAL BOILING POINT 79.0 DRY POINT: MAXIMUM 80.5 NON-VOLATILE RESIDUE (MG/100ML) MAXIMUM 2 APPEARANCE : CLEAN AND FREE VISUAL MAKE SASOL SOLVANT OR EQUVALENT
85	PR1005L	VARNISH	110	LTR	MSDS REQUIRED, REMAINING SHELF LIFE



10 **PAKISTAN AERONAUTICAL COMPLEX**
A SYMBOL OF EXCELLENCE IN AVIATION
www.pac.org.pk



					CERTIFICATE REQUIRED
86	259885-104	RIBBON	AS REQ UIR ED	EA	REQUIRED FOR PRINTER PRINTRONIX P8025
87	1598-300	DIGITAL HIGH GUAGE	1	EA	RANGE 0-24" ACCURACY 0.0005" V block 6"x2" qty (03) BLOCK ACCURACY 0.01MM EXTENSION FOR MEASURING ROD 2" EXTENSION FOR MEASURING ROD 4" EXTENSION FOR MEASURING ROD 6" UNVERSAL SQUARE HOLDING ARM SHANK 11.5X7X71MM TRIMOSE MADE OR EQUIVALENT
88	9520PK0960001	IRON RACK 6X6X3 FEET WITH WHEEL CASTER	6	EA	STEEL RACK STEEL 6X6X3 FEET ALONG WITH RUBBER MAT INSIDE SHELVES
89	6635PK2550003	X-RAY FILM 35.6X43.2CM	2	PKT	MAKE FUJI OR EQUIVALENT 100*PB INDUSTRIAL FILM
90	6635PK2550005	X-RAY FILM 18X24 CM	2	PKT	MAKE FUJI OR EQUIVALENT 100*PB INDUSTRIAL FILM
91	6635PK2550006	X-RAY FILM 24X30 CM	2	PKT	<u>MAKE FUJI OR EQUIVALENT 100*PB INDUSTRIAL FILM</u>
92	16A/NIV-11-3A	A/C REFULER (L/R)	1	EA	SCOPE OF WORK REQUIRED: WELDING OF FUEL BOUSER TANK LEAKAGE FROM REAR SIDE AND CIGIGATION KIT WITH FITTING
93	5810PK2580001	WALKIE TALKI SET REPEATER	2	SET	OPERATING VOLTAGE 11/11/2017220VAC,13.6VDC POWER SUPPLY (EXTERNAL): TO PROVIDE BACKUP FOR ATLEAST 10 MIN IN CASE OF MAIN FAILURE,FREQUENCY RANGE:VHF,NO OF CHANNELS:>16 CHANNELING SPEED:12.5/20/25 KHZ,OPERATING TEMPERATURE,-20 °C TO +55 °C,STORAGE TEMPERATURE:-40 °C TO +85 °C CURRENT DRAIN: STAND BY <1.2 A,TRANSMIT: <12A,RF OUTPUT : 5-45 W (100% CONTINUOUS FULL DUTY CYCLE OPERATION) FREQUENCY STABILITY -20 °C TO +55 °C): ±1.5 PPM HUM AND NOISE 40DB @ 12.5KHZ,45DB@20/25 KHZ,MODULATION LIMITING± 2.5 KHZ @12.5 KHZ,±4.0 KHZ @20 KHZ,±5.0 KHZ @ 25 KHZ,CONDUCTED



11 **PAKISTAN AERONAUTICAL COMPLEX**
A SYMBOL OF EXCELLENCE IN AVIATION
www.pac.org.pk



				<p>/ RADIATED EMISSION : -36 DB <1 GHZ , -30DB >1 GHZ,ADJUCENT CHANNEL POWER,60 DB @12.5 KHZ,70 DB @20/25 KHZ,DIGITAL VOCODER TYPE: AMBE ++ OR SELP,BLOCKING 100DB,SENSITIVITY ANALOGUE DIGITAL: 3.0μV (12DB SINAD)0.22μV (TYPICAL)(12 DB SINAD)0.4 μV (20 DB SINAD), 5% BER: 0.3μV INTERMODULATION 65-70DB,ADJACENT CHANNEL SELECTIVITY: 60DB@12.5 KHZ,70 DB@12/25 KHZ,SPURIOUS REJECTION ,70 DB,AUDIO POWER OUTPUT,0.5 W RATED,AUDIO DISTORTION:@ RATED AUDIO 3% (TYPICAL),AUDIO RESPONSE +1 ~ -3DB,CONDUCTED SPURIOUS EMISSION: <-57 DBM,MODE: DUAL MODE (ANALOGUE + DIGITAL)SHOULD BE COMPATIBLE WITH MOTOROLA GP 2000,ENCRYPTION : ATLEAST RC41 AND PREFERABLY USER CUSTOMIZED 265 BITS AES,MULTICHANNEL: SUPPORT ATLEAST TWO SIMULTANEOUS VOICE OR DATA PATHS IN DIGITAL TDMA MODE,DATA COMMUNICATION : INTEGRATED DATA PORT COMPATIBLE WITH PC ALONG WITH REQUISET SOFTWARE/DRIVER,INTERFACE:FLEXIBLE MENU-DRIVEN INTERFACE WITH USER MEMORY ICONS AND AT LEAST TWO LINES OF TEXT FOR EASE READING TEXT MESSAGE,INDICATOR,COLOUE LED INDICATOR FOR CLEAR ,VISIBLE STATUS INDICATION,DISPLAY,LARGE SIZE TFT COLOUR LCD DISPLAY AND MENU NAVIGATION KNOB TO FACILITATE SERVICE AND MAINTINANCE,,BOTTONS *PROGRAMABLE BUTTONS FOR AGAINST ACCESS TO REQUIRED FEATURES SUCH AS ONE TOUCH CALLING,SEALING,RATED IP54,PROTECTED AGAINST HARM FROM DUST OR WATER SPRAY,HEAT SINK,ALONG WITH THERMAL CONTROLLED COOLING FAN,ANTENA,COMPATIBLE TWO BROADBAND ANTENAS ALONG WITH ATLEAST 150 FEET CABLE (LOW LOSS)EACH..</p>
--	--	--	--	---



PAKISTAN AERONAUTICAL COMPLEX
 12 A SYMBOL OF EXCELLENCE IN AVIATION
www.pac.org.pk





					OPTIONAL FEATURES,MULTI SITE IP CONNECTION,RACK,COMPATIBLE WITH DESKTOP HOUSING,HANDLES , ERGONOMICS AND STUDY HANDLES TO MAKE HANDLING COMFRTABLE,MOBILE DUPLEXER,INTERNAL INSTALLATION.DESKTOP POWER SUPPLY,OPTIONAL,MICROPHONE :PALM MICROPHONE (OPTIONAL KEYPAD)DIRECTIONAL ANTENA:OPTIONAL,DUPLEXER INSTALLATION KIT OPTIONAL,MOUNTING BRACKET / KIT: OPTIONAL WARRANTY MINIMUM 02 YEARS,SPARE & MAINTINANCE SUPPORT FOR 10 YEARS,MILITARY STANDARD: MIL-STD-810C ,D,E,F,G, STANDARD FOR TEMPERATURE,FIRM CAPABLE TO SUPPORT "SERVER FUCTIONALLY" FOR GPS TRACKING AND VOICE RECORDING FEATURES..CLONE CABLE: OPTIONAL
94	NTMN32	TELEPHONE SET(3902)	15	EA	WIDTH:8.50IN(216MM) DEPTH 1:7.75IN(197MM) DEPTH 2:6.75IN (171MM) HEIGHT 1 : 5.13 IN(130MM) HEIGHT 2 : 7.00 IN(178MM) WEIGHT :1.8 LB (0.82KG) COLOR:CHARCOAL OR ASH TEMP:0B: C TO 50B: C (32B:F TO 122B:F RELATIVE HUMIDITY:5% TO 95 % AUXY POWER: (3902 AND M3904 ONLY) LOCAL PLUG-IN AC TRANSFORMER FOR CARTRIDGE-STYLE ACCESORIES LOOP LENGTH: 4000 FT (1220M) 24 AWG STANDARD: MEETS OR EXCEEDS APPLICABLE CSA , UL AND EIA SPECIFICATION.COMPLIES WITH FCC REQUIREMENTS FOR HEARING AID COMPATIBLITY . MAXIMUM HANDSET VOLUME CONTROL LEVEL ARE COMPLIANT WITH AMERICANS WITH DISABILITIES ACT (ADA)
95	32410-0040	PRESSURE LIMITING VALVES MV41 BR/0.500 BAR+M18X1.5	1	EA	MADE HAWA / HYCOM OR EQUIVALENT
96	11-6764	PLIERS DIAGONAL GROUNDING	1	EA	



13 **PAKISTAN AERONAUTICAL COMPLEX**
A SYMBOL OF EXCELLENCE IN AVIATION
www.pac.org.pk



97	5510PK0960002	WORKING TABLE	8	EA	<p>HEIGHT OF TABLE WITHOUT GUTKA=3' LENGTH OF TABLE=7'.6" WIDTH OF TABLE=3'.6" THICKNESS OF UPPER FACE=2" WIDTH OF ONE SIDE INCLUDING 02 DRAWS=2'.6" NO OF GUTKA(SUPPORT) TOTAL=8 WIDTH OF GUTKA=2" HEIGHT OF GUTKA=3" TOTAL NUMBER OF DRAWS=04 SMALL 04 DRAWS SLIDE & 04 DRAWS EACH SIDE WITH LOCKS HOLDING STAND 3'.6" WHICH FRONT WIDTH 2" & SIDE WIDTH 6" HOLDING STAND TOP COVER WIDTH 11"</p>
----	---------------	---------------	---	----	---

 <p>جہان تازہ کی اوجھار تازہ سے نمود</p>	<p>PAKISTAN AERONAUTICAL COMPLEX</p> <p>14 A SYMBOL OF EXCELLENCE IN AVIATION</p> <p>www.pac.org.pk</p>	 <p>جہان تازہ کی اوجھار تازہ سے نمود</p>
---	--	---

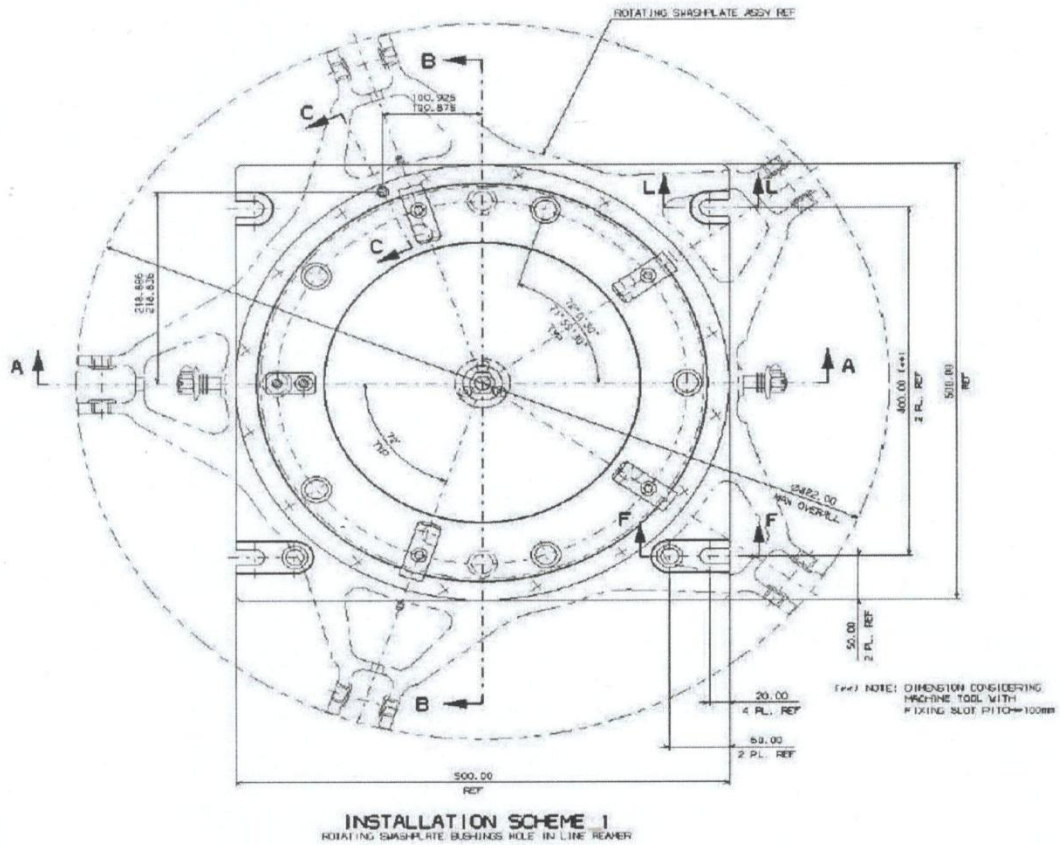

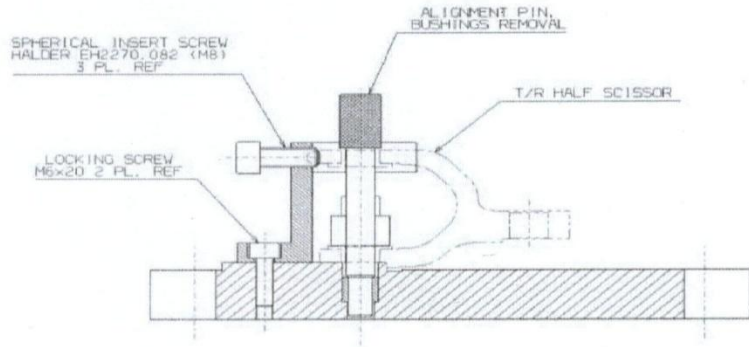

SECTION A-A
HALF SCISSOR LOCKING SCHEME
(BUSHINGS MILLING FOR REMOVAL)

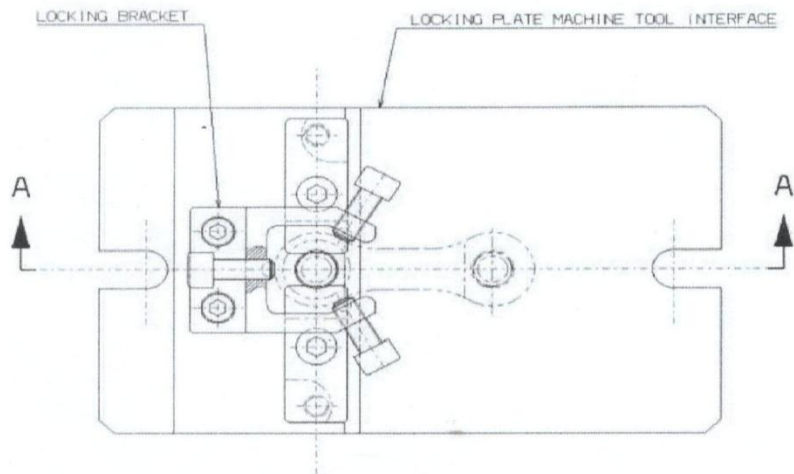

Pagina 2 di 7



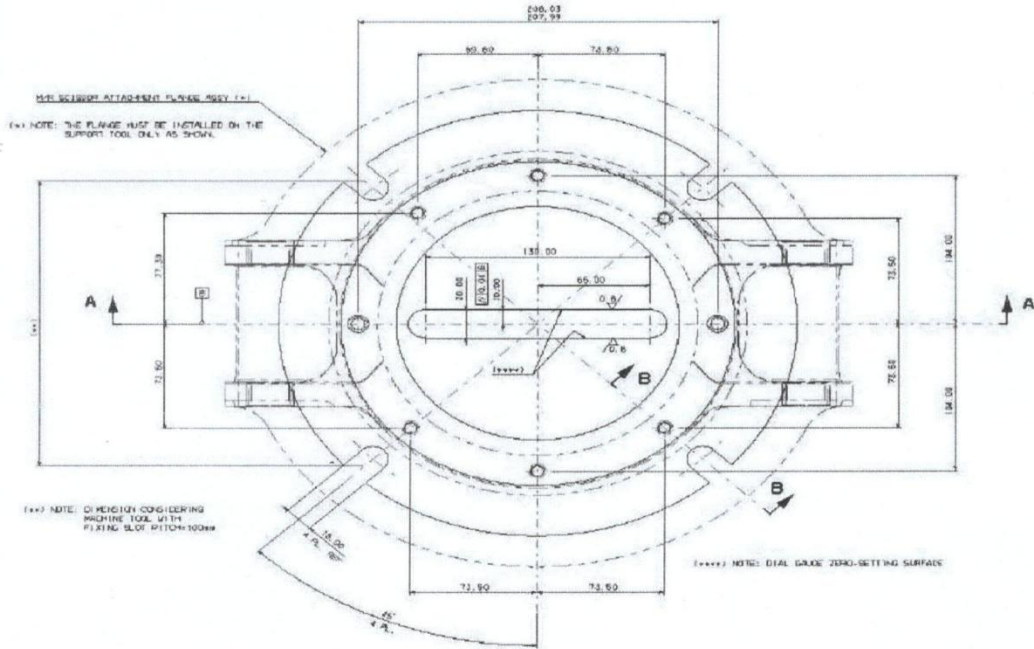

Pagina 2 di 4

Ref.: FG/2016/048

Page 2 of 4



PAKISTAN AERONAUTICAL COMPLEX
 17A SYMBOL OF EXCELLENCE IN AVIATION

www.pac.org.pk



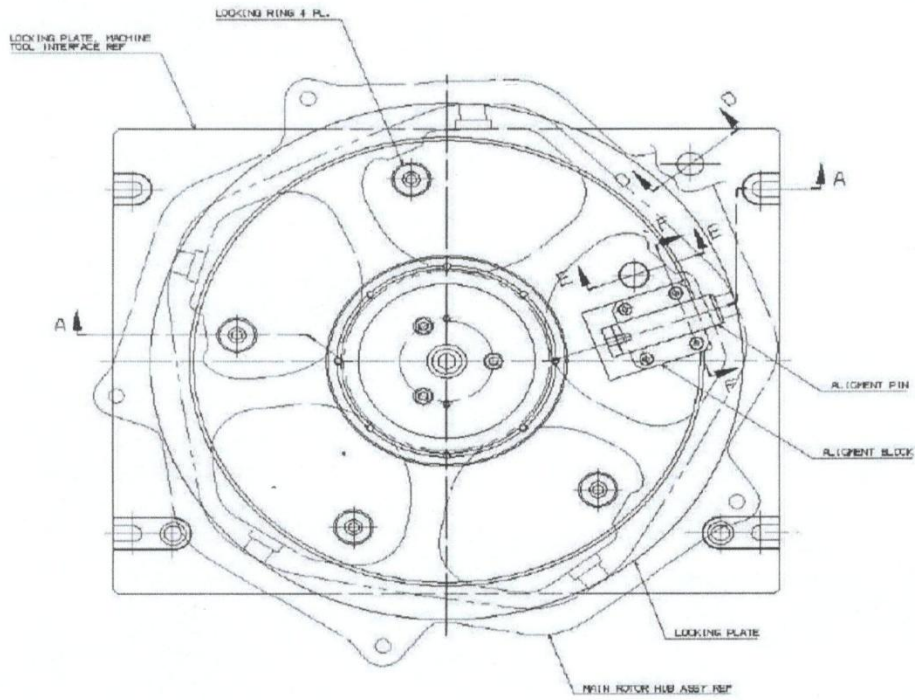

INSTALLATION SCHEME



TERMS & CONDITIONS:-

- (i) GST may be indicated separately. The envelopes must be marked with "Item's name and Commercial / Technical offer". Literature / brochures of equipment must be attached with technical offer.
- (ii) Quotations must be submitted in two copies for single line item i.e. one copy with technical details without price and one copy as commercial offer in one envelopes (no quotation will be accepted if it contains more than 01 item in a single quotation)
- (iii) Validity period should not be less than 90 days.
- (iv) Complete technical specifications, MSDS, OEM & Conformance Certificate, Calibration certificate, Fitness report where applicable are required. Sample of chemicals may be asked for test.
- (v) Quotation received after due date / time will not be entertained. The CFA reserves the right to accept / reject the part or whole tender.
- (vi) Professional Tax certificate, Punjab is mandatory.
- (vii) Quantity can be increased / decreased at the time of order as per our requirement.

Directorate of Logistics MRF, PAC Kamra
Contact No. 051-90994294 & 4414, Fax No. 057-9317412

